



ISO 9001
Certification



ISO 14001
Certification



OHSAS 18001
Certification



European CE
Certification



New Technology
Certification

HEAD OFFICE & FACTORY

128, Chungjusan-dan 1-ro, Chungju-si, Chungcheongbuk-do, 27329, Korea

SEOUL OFFICE (GLOBAL SALES DIV.)

5F, East Bldg., Hyundai Group Bldg., 194, Youlgok-ro, Jongno-gu, Seoul, 03127, Korea

AFRICA

EGYPT

T 2-02-61139863
E a.abdelrehim@ElsewedyMachinery.com

ETHIOPIA

T 251-911-503-000
E ieethiopia1@gmail.com

KENYA

T 254-722-667984
E charles.skymax@africaonline.co.ke
pslyall@skymaxenterprise.com

MOROCCO

T 212-522-490-485
E commercial@luxurylift.net

NIGERIA

T 234-7034444400
E joseph@liftline.co

TUNISIA

T 212-71-962-967
E ideal.commerciale@gmail.com

ASIA

BANGLADESH

T 88-017-13209212
E zahid@edgeworksbd.com

CAMBODIA

T 855-23-888-399
E project@ggear.com.kh

CHINA

[Head Office (Factory)]
T 86-21-6485-8600
E 2017407@hdel.co.kr

INDIA

T 91-99-7000-0611
E rdmello@kinetic-hyundai.com

INDONESIA

[Service]
T 62-21-3511-355
E marketing@helin.co.id

[New Equipment]

T 62-21-631-8444
E sugiono_nusalim@yahoo.com

MALAYSIA

T 603-7932-1326
E ku.lee@hdel.co.kr
sales@hem.com.my

MONGOLIA

T 976-8908-3031
E munkhtuya@hyundai-elevator.mn

MYANMAR

T 951-2305336-37
E info@integral-ltd.com

PAKISTAN

T 92-21-3432-0601-5
E iitcpk@gmail.com

PHILIPPINES

T 632-8716-0905
E sales@hyundaielevator.com.ph

SRI LANKA

T 94-11-2623208
E wasantha@abansgroup.com

THAILAND

T 66(0)-2240-3127-8
E ratee@loxley.co.th

VIETNAM

T 84-945-977-417
E ku.lee@hyundaielevator.com

EUROPE & CIS

ALBANIA

T 355-69-331-9597
E info@safetylevators.al

AZERBAIJAN

T 994-50-207-2217
E info@s-enna.az

DENMARK

T 45-3311-3230
E office@s-elevator.com

GREECE

T 210-481-8756
E info@valsalift.gr

KAZAKHSTAN

T 7-701-599-9906
E dmitriy@hdel.kz

KYRGYZSTAN

T 996-707-646-666
E hyundaielevatorskg@gmail.com

POLAND

T 48-61-820-85-51
E maciej.dziurkiewicz@omilifts.com

ROMANIA

T 40-231-537-138
E office@smartelevators.eu

TÜRKIYE

T 90-216-510-1244
E orkun.tanman@hdel.com.tr

UZBEKISTAN

T 998-90-910-1368
E innesa@boinncorp.com

MIDDLE EAST

BAHRAIN

T 973-1770-2468
E elevators@nassgroup.com

IRAQ

T 964-79-1336499
E info@alarjoon.com

ISRAEL

T 972-3-9630000
E Avia@ledico.com

JORDAN

T 962-79-5526-713
E maadbseiso55@gmail.com

KUWAIT

T 965-2227-0722
E info@dealgt.com

T 965-6611-1955

E s.saleem@atlaslifts.net

OMAN

T 968-9936-9663
E techno.hyundai@gmail.com

QATAR

T 974-4436-6689,
974-4427-9565
E info@ietg-hyundaielevator.com

SAUDI ARABIA

T 966-12-263-1907
E shoukath@escoco.com.sa

UAE

T 971-4-294-4475
E dubai@bhnoe-hyundai.com

NORTH / SOUTH AMERICA

ARGENTINA

T 5411-3220-2878,
5411-4488-1948
E ogueta@skylift.com.ar

BRAZIL

T 55-11-5070-4141
E wellington.sierra@hdel.com.br

CHILE

T 56-9-225540849
E lcid@cyce.cl

COLOMBIA

T 57-4-444-9297
E sgiraldo@solucionesverticales.com.co

COSTARICA

T 506-2291-0455
E mv.elevatec@grupomisol.com

DOMINICAN REPUBLIC

T 809-566-7474
E cesar@eleva.com.do

ECUADOR

T 593-2254-2831
E hyundai@a-i.com.ec

EL SALVADOR

T 503-2260-6233
E jc.elevatec@grupomisol.com

GUATEMALA

T 502-2388-0000
E cd.elevatec@grupomisol.com

HONDURAS

T 504-2564-6150,
504-2231-3302
E jc.elevatec@grupomisol.com

MEXICO

T 52-55-5663-2019
E yurich@insertechmx.com

NICARAGUA

T 505-2223-5217
E bb.elevatec@grupomisol.com

PANAMA

T 507-381-7422,
507-381-7427
E el.elevatec@grupomisol.com

PERU

T 506-7013-4407
E cc.elevatec@grupomisol.com

PARAGUAY

T 595-2120-1915
E egrau@inelec.com.py

USA & CANADA

T 812-705-4057
E Sales@ALT-AVT.com

VENEZUELA

T 58-212-232-8263
E ojssimon@gmail.com

HYUNDAI ELEVATOR CO., LTD.

This publication is for general informational purposes only and the company reserves the right to alter product design and specifications at any time.

Notes

1. Product images have been modified to help viewers' understanding. Design and colors depicted may differ from the actual products'.
2. Specifications may differ from those provided in printed materials due to the selection of options or quality improvements.
3. Copyright © HYUNDAI ELEVATOR CO., LTD. All rights reserved.
4.  Please recycle this brochure to protect the environment.

Website



YouTube



N:EX-1

H-BELT DRIVE SYSTEM

HYUNDAI
ELEVATOR CO., LTD.

SMART MANUFACTURING IS THE KEY TO SAFER AND MORE RELIABLE MANUFACTURING

Full automatic manufacturing ensures high product quality

Real-time manufacturing monitoring

Enables accurate delivery schedule projections for easier project management.

Automation

A closed-loop control system (an automatic system that regulates processes for desired goals without human interaction) manages raw material stock, storage, production, loading, and shipping automatically for the highest possible efficiency.

Lean Manufacturing

Smart manufacturing minimizes waste and achieves maximum productivity.

Flexibility

Advanced and cutting-edge manufacturing machines can help meet customers' customized requirements.

03 Intro

04 H-BELT Drive system

06 Car Design

- 01 URBAN GREY
- 02 SOFT ROSE
- 03 IVORY HARMONY
- 04 MODERN MARBLE
- 05 CLASSIC SILVER
- 06 GLAM BRONZE

20 Clean Moving Solution

22 Fixture Design

26 Specification

- Installation Layout Plan
- Functions
- Work to be done by others

How do we make an elevator that is both efficient and eco-friendly?

We rely on elevators every day. How can we elevate the experience, making it smarter, cleaner and safer?

How can we harmonize aesthetic design with rigorous engineering requirements?

N:EX-1 is the solution.

N:EX-1

New + Experience + X(Everything)+ 1(to the Global No.1)

N:EX-1 is a next generation elevator with environmentally friendly belt and latest mobility technology.

HYUNDAI ELEVATOR presents a new elevator experience.

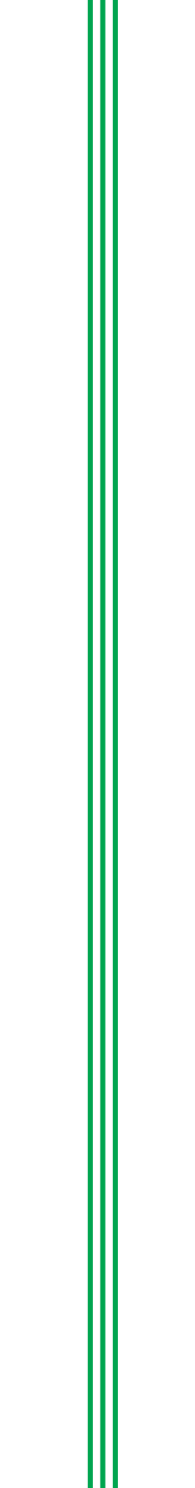

HYUNDAI
ELEVATOR
N:EX-1



Eco-Friendly Innovation:

Experience the most advanced belt drive system, powered by next-generation green technology.

The H-BELT Drive System is HYUNDAI ELEVATOR's innovative, next-generation, eco-friendly technology that utilizes belts instead of the traditional steel wire ropes. The belt has longer life span, saves energy and enhances performance.

Extended Lifespan

The high-quality steel belt drive ensures a smooth and stable operation.

H-BELT offers extended lifespan of steel wire ropes and weighing 40% less. It is highly corrosion resistant and lubrication-free. The belt break detection system guarantees safety and reliability.



Smooth Riding & Safety

Innovative crown shape drum designing

The key to a smooth and safe riding experience lies in the traction machine's crown shaped drum. This unique design ensures the belt constantly returns to the center automatically.

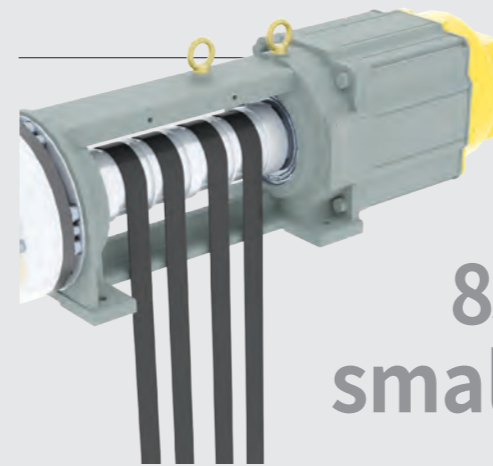
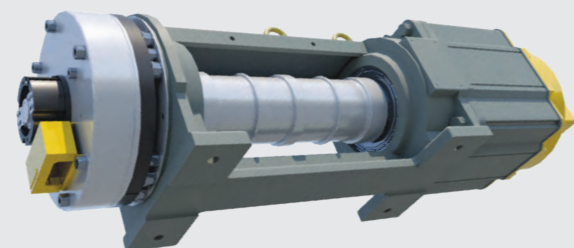

85% smaller

Compact

Small but powerful TM

The compact design of our TM, made possible by H-BELT's smaller bending radius compared to the wire rope, reduced the overall size by 85%. This space-saving feature allows for higher, more comfortable elevator cabins.

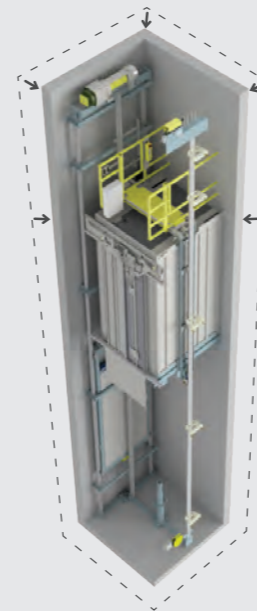

8% smaller

Efficient use of hoistway

Our innovative H-BELT Drive System reduces elevator shaft size by up to 8%, allowing for more flexible building design and increased usable space.

Eco-Friendly

Environmentally sustainable and lubricant-free

While steel ropes require regular oil maintenance due to their material properties, H-BELT eliminates the need for oil, offering easier maintenance and a more environmentally friendly solution.



Zero Oil

N:EX-1 CAR DESIGN

Introducing the all-new N:EX-1 Car Design.

N:EX-1 combines elegant design with eco-friendly technology.

Available in a range of colors and materials,
it offers a visually appealing and energy-efficient solution.

URBAN GREY

DARK GREY & GREY # MODERN # CHIC



SOFT ROSE

PALE ROSE & WHITE # SOFT # WARM



IVORY HARMONY

GOLD & IVORY # WARM # COZY



MODERN MARBLE

MARBLE & SILVER # MODERN # STYLISH



CLASSIC SILVER

SILVER & ETCHING # CLASSIC # ELEGANT



GLAM BRONZE

TITANIUM BRONZE # GLAMOROUS # GORGEOUS



01 URBAN GREY

DARK GREY & GREY # MODERN # CHIC

CAR DESIGN



Rear View



Front View

SPECIFICATION

CEILING	CD-S14A
FRONT WALL	PAINTED STEEL (P021)
SIDE WALL	PAINTED STEEL (P021, P038)
REAR WALL	PAINTED STEEL (P038)
CAR DOORS	PAINTED STEEL (P021)
HANDRAILS	HR-01W
CAR OPERATION PANEL	OPP-D564T
FLOORING	PVC (H07)

ENTRANCE



200 Type

JAMB	PAINTED STEEL (P038)
TRANSOM PANEL	PAINTED STEEL (P038)
HALL DOORS	PAINTED STEEL (P038)
HALL BUTTON	HPB-J21
INDICATOR	PI-S700

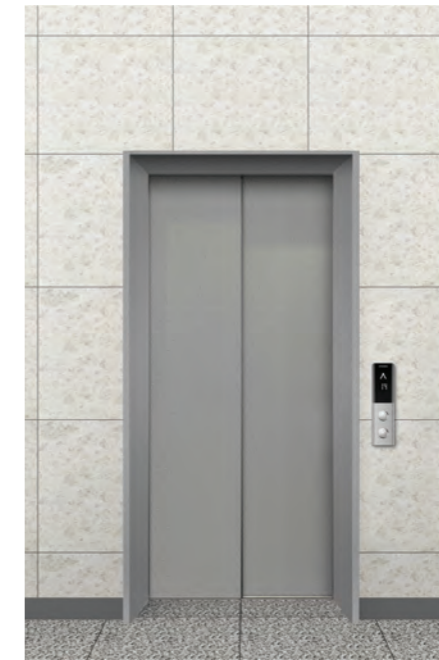

100 Type

JAMB	PAINTED STEEL (P038)
HALL DOORS	PAINTED STEEL (P038)
HALL BUTTON	HIP-SJ21

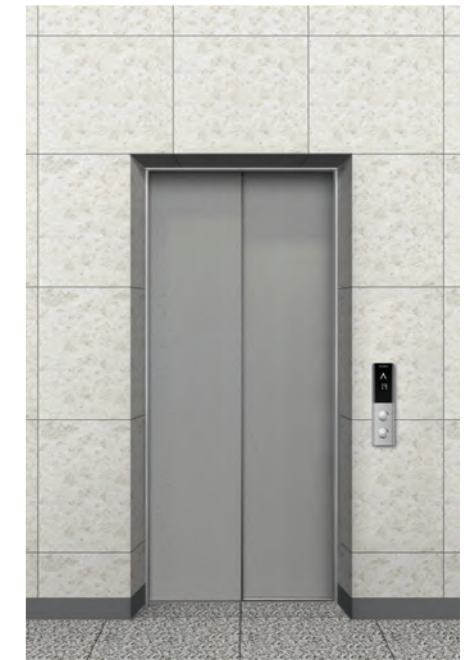

50 Type

JAMB	PAINTED STEEL (P038)
HALL DOORS	PAINTED STEEL (P038)
HALL BUTTON	HIP-SJ21

MATERIAL

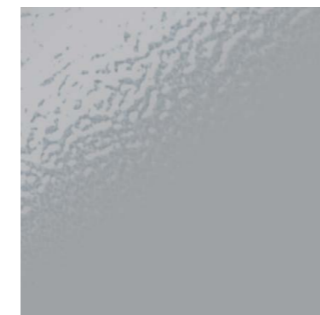

P021

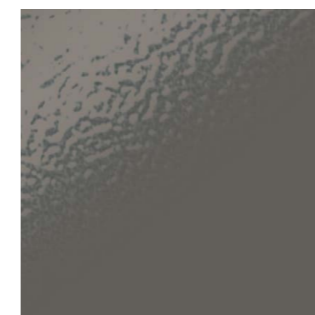

P038

- Note**
- The standard Car Height is 2,300mm and Entrance Height is 2,100mm. The car indicator can only be applied for a Car Height 2,400mm or more.
 - Product and design images are for illustrative purposes only. Actual product colors may vary.
 - Ceiling and wall divisions may vary according to passenger capacity.
 - The pattern arrangement may vary according to passenger capacity.
 - An emergency elevator cabin is equipped with a ladder hatch.
 - Ceiling emergency trap door are fabricated only for firefighting and rescue purposes.

02 SOFT ROSE

PALE ROSE & WHITE # SOFT # WARM

CAR DESIGN

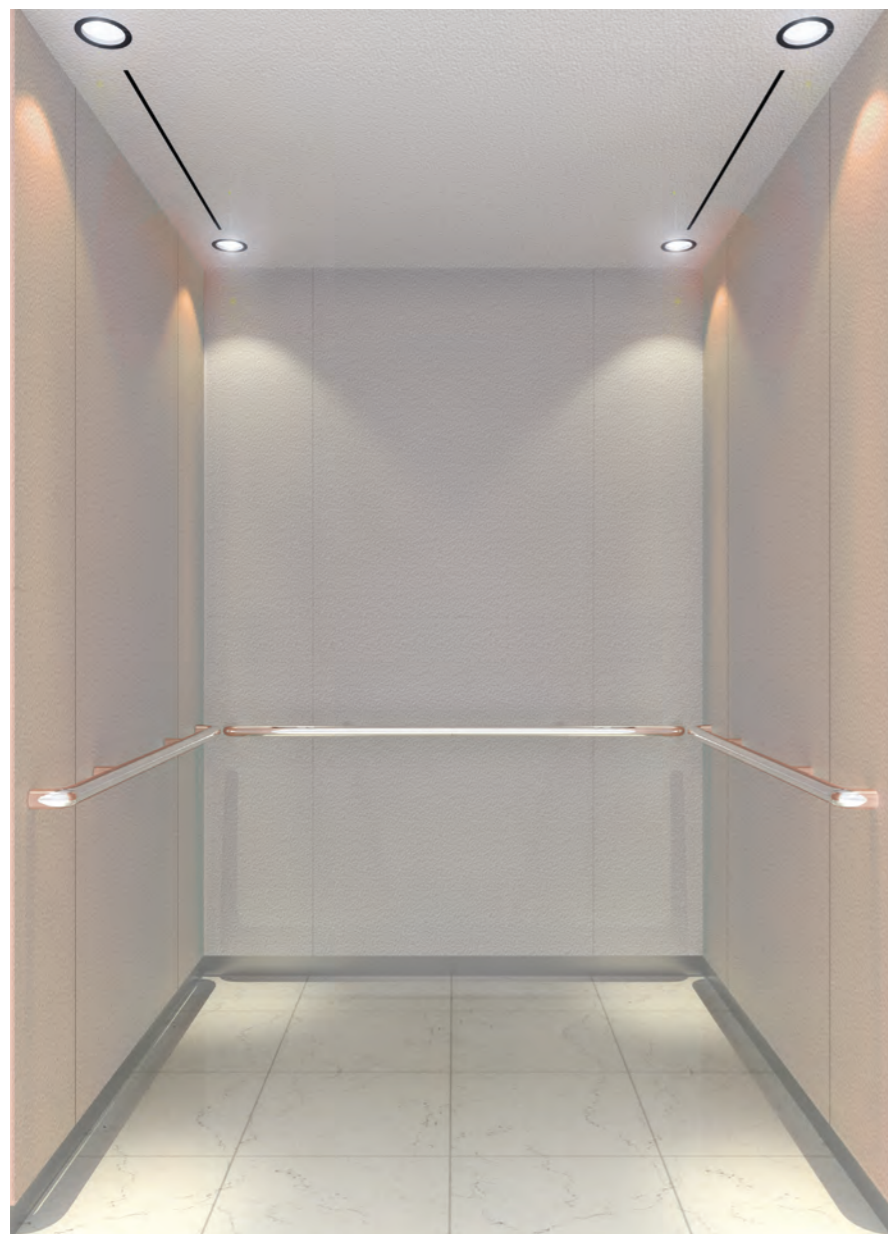

Rear View



Front View

SPECIFICATION

CEILING	CD-S14A
FRONT WALL	PAINTED STEEL (P040)
SIDE WALL	PAINTED STEEL (P034)
REAR WALL	PAINTED STEEL (P040)
CAR DOORS	PAINTED STEEL (P040)
HANDRAILS	HR-01W
CAR OPERATIONG PANEL	OPP-D521
FLOORING	PVC (H01)

ENTRANCE



200 Type

JAMB	PAINTED STEEL (P040)
TRANSOM PANEL	PAINTED STEEL (P040)
HALL DOORS	PAINTED STEEL (P040)
HALL BUTTON	HPB-J21
INDICATOR	PI-S700

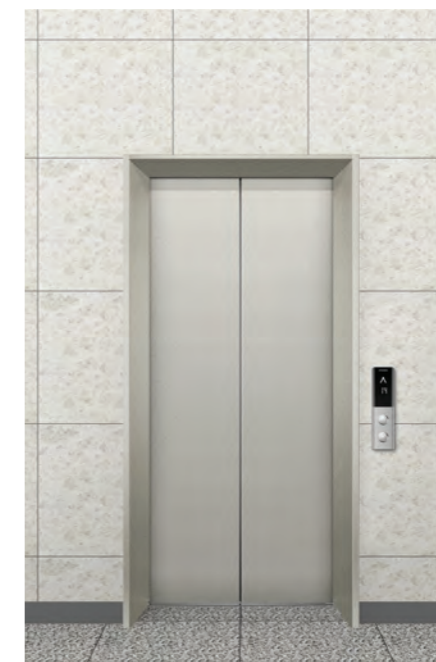

100 Type

JAMB	PAINTED STEEL (P040)
HALL DOORS	PAINTED STEEL (P040)
HALL BUTTON	HIP-SJ21

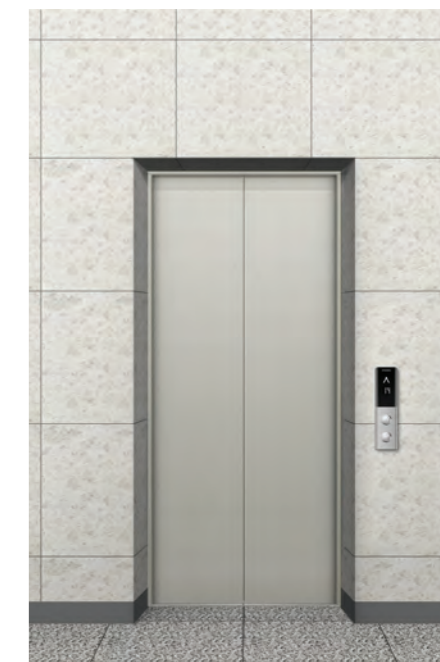

50 Type

JAMB	PAINTED STEEL (P040)
HALL DOORS	PAINTED STEEL (P040)
HALL BUTTON	HIP-SJ21

MATERIAL



P034

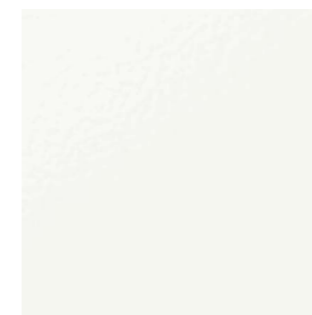

P040

Note -The standard Car Height is 2,300mm and Entrance Height is 2,100mm. The car indicator can only be applied for a Car Height 2,400mm or more.

- Product and design images are for illustrative purposes only. Actual product colors may vary.
- Ceiling and wall divisions may vary according to passenger capacity.
- The pattern arrangement may vary according to passenger capacity.
- An emergency elevator cabin is equipped with a ladder hatch.
- Ceiling emergency trap door are fabricated only for firefighting and rescue purposes.

03 IVORY HARMONY

GOLD & IVORY # WARM # COZY

CAR DESIGN



Rear View



Front View

SPECIFICATION

CEILING	CD-S54A
FRONT WALL	PAINTED STEEL (P036)
SIDE WALL	PAINTED STEEL (P040)
REAR WALL	PAINTED STEEL (P036)
CAR DOORS	PAINTED STEEL (P036)
HANDRAILS	HR-01W
CAR OPERATION PANEL	OPP-D521
FLOORING	PVC (H07)

ENTRANCE



200 Type

JAMB	PAINTED STEEL (P036)
TRANSOM PANEL	PAINTED STEEL (P036)
HALL DOORS	PAINTED STEEL (P036)
HALL BUTTON	HPB-J21
INDICATOR	PI-S700

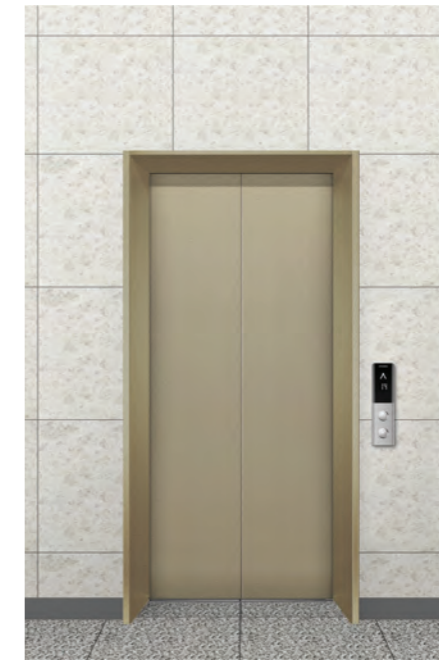

100 Type

JAMB	PAINTED STEEL (P036)
HALL DOORS	PAINTED STEEL (P036)
HALL BUTTON	HIP-SJ21

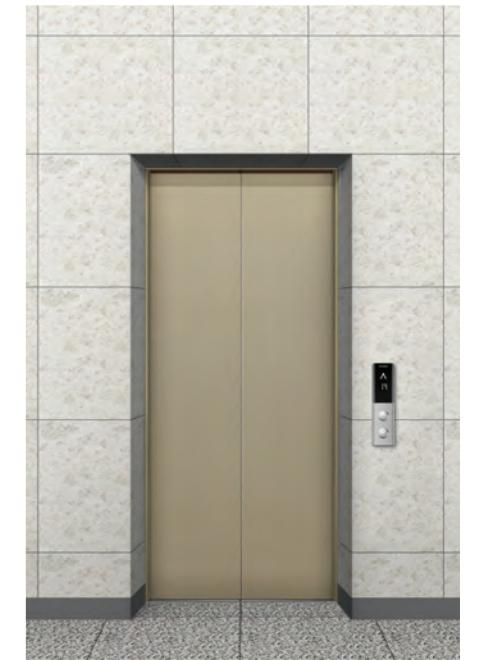

50 Type

JAMB	PAINTED STEEL (P036)
HALL DOORS	PAINTED STEEL (P036)
HALL BUTTON	HIP-SJ21

MATERIAL



P036

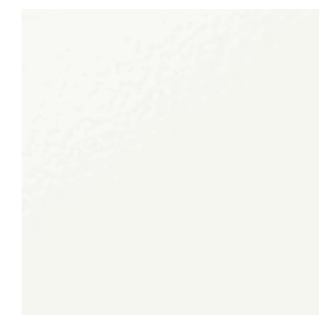

P040

- Note**
- The standard Car Height is 2,300mm and Entrance Height is 2,100mm. The car indicator can only be applied for a Car Height 2,400mm or more.
 - Product and design images are for illustrative purposes only. Actual product colors may vary.
 - Ceiling and wall divisions may vary according to passenger capacity.
 - The pattern arrangement may vary according to passenger capacity.
 - An emergency elevator cabin is equipped with a ladder hatch.
 - Ceiling emergency trap door are fabricated only for firefighting and rescue purposes.

04 MODERN MARBLE

MARBLE & SILVER # MORDEN # STYLISH

CAR DESIGN



Rear View



Front View

SPECIFICATION

CEILING	CD-S54A
FRONT WALL	STS HAIRLINE, STS MIRROR
SIDE WALL	STS HAIRLINE
REAR WALL	STS HAIRLINE, VCM (SW12)
CAR DOORS	STS HAIRLINE
HANDRAILS	HR-01W
CAR OPERATIONG PANEL	OOPP-L521 / STS MIRROR
FLOORING	PVC (H02)

ENTRANCE



200 Type

JAMB	STS HAIRLINE
TRANSOM PANEL	STS HAIRLINE
HALL DOORS	STS HAIRLINE
HALL BUTTON	HPB-J21
INDICATOR	PI-S700



100 Type

JAMB	STS HAIRLINE
HALL DOORS	STS HAIRLINE
HALL BUTTON	HIP-SJ21

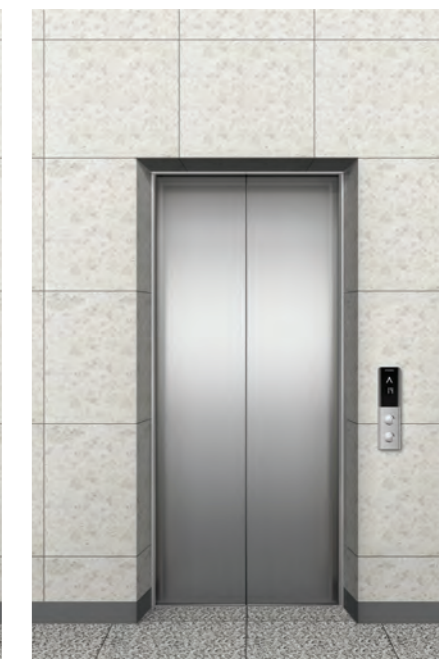

50 Type

JAMB	STS HAIRLINE
HALL DOORS	STS HAIRLINE
HALL BUTTON	HIP-SJ21

MATERIAL



STS HAIRLINE



STS MIRROR

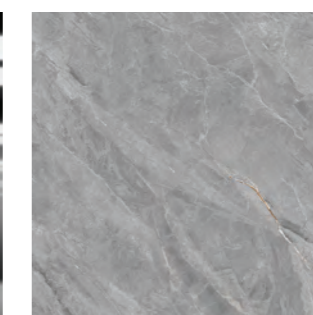

VCM (SW12)

- Note**
- The standard Car Height is 2,300mm and Entrance Height is 2,100mm. The car indicator can only be applied for a Car Height 2,400mm or more.
 - Product and design images are for illustrative purposes only. Actual product colors may vary.
 - Ceiling and wall divisions may vary according to passenger capacity.
 - The pattern arrangement may vary according to passenger capacity.
 - An emergency elevator cabin is equipped with a ladder hatch.
 - Ceiling emergency trap door are fabricated only for firefighting and rescue purposes.

05 CLASSIC SILVER

SILVER & ETCHING # CLASSIC # ELEGANT

CAR DESIGN



Rear View



Front View

SPECIFICATION

CEILING	CD-199A
FRONT WALL	STS HAIRLINE
SIDE WALL	STS HAIRLINE
REAR WALL	STS HAIRLINE, STS HAIRLINE ETCHING (SE4556)
CAR DOORS	STS HAIRLINE ETCHING (SE4556)
HANDRAILS	HR1NSS0
CAR OPERATION PANEL	OPP-L521
FLOORING	PVC (H01, H06)

ENTRANCE



200 Type

JAMB	STS HAIRLINE
TRANSOM PANEL	STS HAIRLINE
HALL DOORS	STS HAIRLINE ETCHING (SE4556)
HALL BUTTON	HPB-J21
INDICATOR	PI-S700



100 Type

JAMB	STS HAIRLINE
HALL DOORS	STS HAIRLINE ETCHING (SE4556)
HALL BUTTON	HIP-SJ21



50 Type

JAMB	STS HAIRLINE
HALL DOORS	STS HAIRLINE ETCHING (SE4556)
HALL BUTTON	HIP-SJ21

MATERIAL

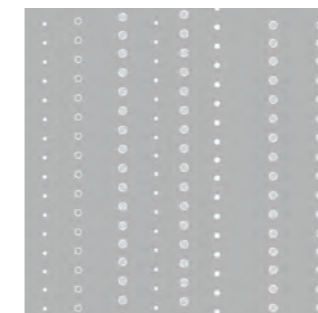

SE4556



STS HAIRLINE

- Note**
- The standard Car Height is 2,300mm and Entrance Height is 2,100mm. The car indicator can only be applied for a Car Height 2,400mm or more.
 - Product and design images are for illustrative purposes only. Actual product colors may vary.
 - Ceiling and wall divisions may vary according to passenger capacity.
 - The pattern arrangement may vary according to passenger capacity.
 - An emergency elevator cabin is equipped with a ladder hatch.
 - Ceiling emergency trap door are fabricated only for firefighting and rescue purposes.

06 GLAM BRONZE

#TITANIUM BRONZE #GLAMOROUS #GORGEOUS

CAR DESIGN

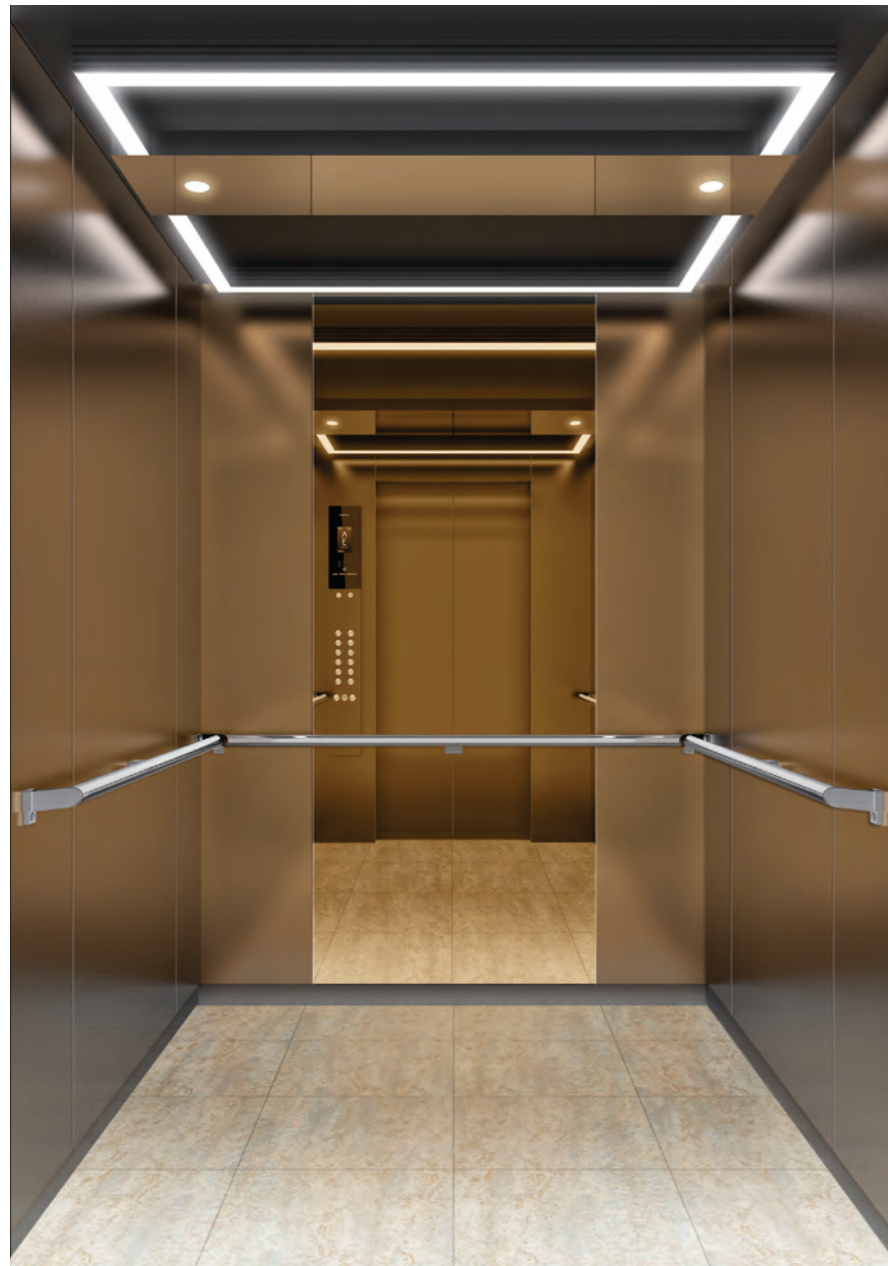

Rear View



Front View

SPECIFICATION

CEILING	CD-S21A
FRONT WALL	TI-BRONZE BEAD BLAST
SIDE WALL	TI-BRONZE BEAD BLAST
REAR WALL	TI-BRONZE BEAD BLAST, TI-BRONZE MIRROR
CAR DOORS	TI-BRONZE BEAD BLAST
HANDRAILS	HR1NSS0
CAR OPERATIONG PANEL	OPP-L521
FLOORING	PVC (H07)

ENTRANCE



200 Type

JAMB	TI-BRONZE BEAD BLAST
TRANSOM PANEL	TI-BRONZE BEAD BLAST
HALL DOORS	TI-BRONZE BEAD BLAST
HALL BUTTON	HPB-B21
INDICATOR	PI-DC

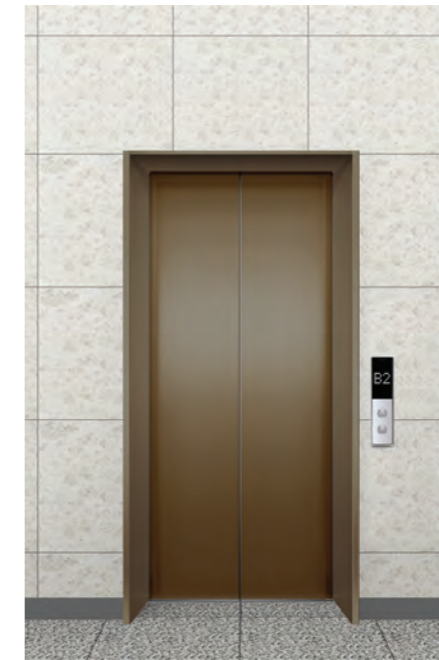

100 Type

JAMB	TI-BRONZE BEAD BLAST
HALL DOORS	TI-BRONZE BEAD BLAST
HALL BUTTON	HIP-DB21



50 Type

JAMB	TI-BRONZE BEAD BLAST
HALL DOORS	TI-BRONZE BEAD BLAST
HALL BUTTON	HIP-DB21

MATERIAL

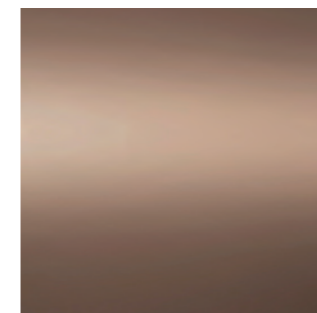

TI BRONZE BEAD BLAST



TI BRONZE MIRROR

- Note**
- The standard Car Height is 2,300mm and Entrance Height is 2,100mm. The car indicator can only be applied for a Car Height 2,400mm or more.
 - Product and design images are for illustrative purposes only. Actual product colors may vary.
 - Ceiling and wall divisions may vary according to passenger capacity.
 - The pattern arrangement may vary according to passenger capacity.
 - An emergency elevator cabin is equipped with a ladder hatch.
 - Ceiling emergency trap door are fabricated only for firefighting and rescue purposes.

CLEAN MOVING SOLUTION

MOTION CALL BUTTONS



Intuitive Motion Control
Experience the future of touchless control with our motion sensor technology. Simple hand gestures, up or down, are all it takes.
* Virtual images are for reference only.



Contactless Control
Maintain hygiene with our surface touch hall buttons. Activate the buttons using your elbow for a touch free experience.
* Images are for reference only.

HPB-DS1D



HIP-DDS1D

Touchless Call Buttons

Reduce the spread of germs with our touchless call buttons. Simple hand gestures activate the buttons without physical contact.

SMART INDICATOR

The Smart Indicator provides comprehensive insights into all aspects of an elevator's operation.

Newly developed by Hyundai Elevator, it provides a wide range of smart functions that optimize the safety and cleanliness of an elevator, ranging from a comprehensive display unit that shows the elevator's current floor, power saving, and CCTV operations to ultrasonic pest control and ozone-free anion air cleaning.



PI-L210



PI-D90



Surveillance Monitoring



Ultrasonic Pest Repellent Function



Power-saving Operation (Regenerative Drive)



Ozone-free Anion Air Purifier

Note - Applicable inside the car only.

AIR TOUCH

Keep Your Elevators Clean and Safe with Touchless Control.

In a time that demands spaces to remain virus free, keep your elevators cleaner and smarter with Air Touch, Hyundai Elevator's exclusive position sensor system.



Safe and Sanitary Operation

Touchless floor selection with Position Sensors



Fast and Accurate Recognition

Swift and reliable operation, even with gloves



Advanced Error Prevention

Protects against unintentional button presses



How it works

Air Touch's advanced infrared sensors, positioned at precise 2mm intervals, enable accurate detection of hand gestures. This sophisticated technology allows users to select their desired floor with ease.



Note - A virtual image has been used to illustrate the sensor's detection area, which is invisible to the naked eye.

FOOT BUTTON

Call the elevator without using your hands with a touchless foot button

Our innovative foot button sensor offers a touchless and hygienic way to call the elevator, especially when your hands are full. This advanced technology ensures a safer and more convenient experience for all users.

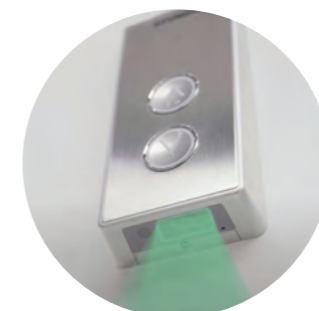

HPB-D64F

How it works

Our patented foot button sensor utilizes advanced technology to detect foot movements. By simply stepping on the laser shot foot symbol on the floor, you can easily call the elevator.



HIP-DB64F

Note - Product images have been modified to help viewers' understanding. Design and colors depicted may differ from the actual products.

FIXTURE DESIGN

CAR OPERATION PANELS

N: NO INDICATOR TYPE / D: DOT TYPE / L: LCD TYPE

STANDARD TYPE

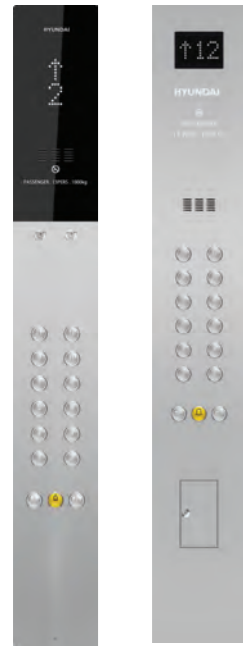

OPP-D521
OPP-L521
OPP-N221
OPP-D221A
OPP-L221

SWING TYPE



OPP-LT221SW
OPP-DW221SW

LCD DESIGN



7 inch LCD

* Please refer to the LCD design when selecting an LCD applicable model.

FOR THE DISABLED



OPP-N521W



OPP-N221BW

* These two panels do not comply to EN81-70 requirements.

HALL BUTTONS

STANDARD TYPE



HIP-SJ21/
HPB-J21
HIP-SK21/
HPB-K21
HIP-DB21/
HPB-B21

GLASS TYPE



HIP-SM21B/
HPB-M21B

FOOT BUTTON TYPE



HIP-DB64F/
HPB-B64F

MOTION CALL



HIP-DDS1D/
HPB-DS1D

INDICATORS

STANDARD TYPE



PI-S700



PI-D700



PI-SC



PI-DC

SMART INDICATOR



PI-D90 (Built-in Type)



PI-L210 (Built-in Type)

Note - Indicators inside the car is only applicable when the car height is 2,400mm or higher.

GLASS TYPE



PI-SM0B

LCD TYPE



LCD (10.4, 12.1, 15.1, 17 inch available)

BUTTONS



21



64



82



94



* Available buttons may vary based on the specific car operation panels or hall buttons selected. For more information or to discuss your specific needs, please contact us directly.

EN 81-70

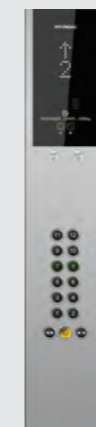

OPP-D564T /
OPP-L564T



OPP-D264T /
OPP-L264T



HIP-DB64 /
HPB-B64



EN64

EN 81-72



OPP-BCK481



HIP-BXK481



64

FIXTURE DESIGN

CEILING

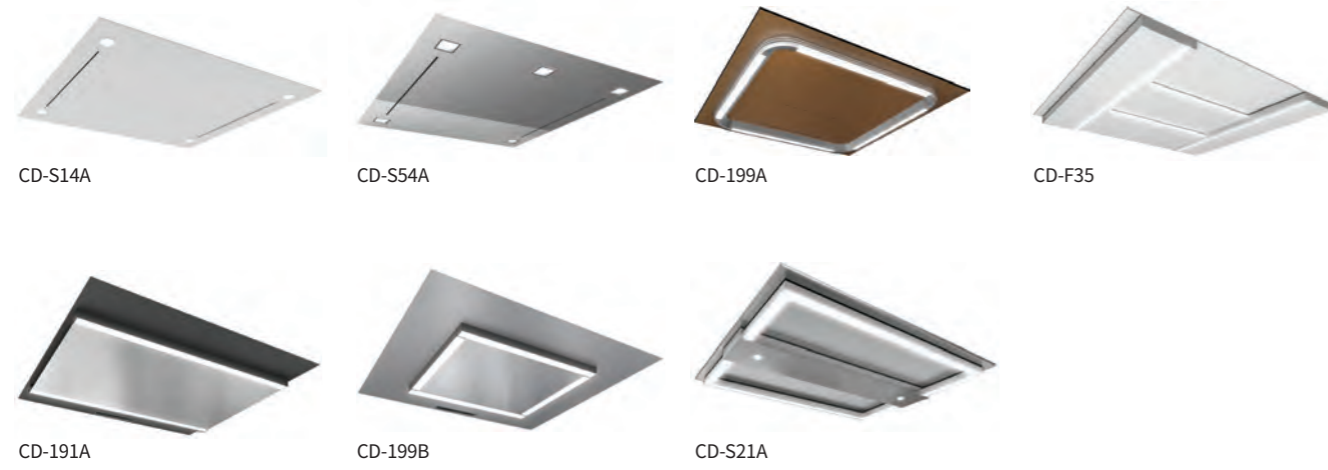

* Availability of an emergency trap door on the ceiling imposes certain limitations on the car size and the feasibility of a double entrance.
For more detailed dimensional information, please contact us.

HANDRAILS

STANDARD TYPE

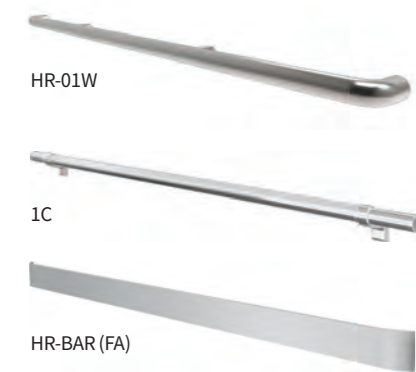

ANTI VIRUS TYPE



* Only HR-01W and HR1NSS0 complies with EN81-70
* 1C type is also available with STSMIR and STSHL_Ti (three colors available, Antique Copper, Black Titanium, Titanium Gold)

HALL LANTERNS



HLS-790
Light Color:
Up-Green, Down-Orange

HLS-770
Light Color:
Up-Green, Down-Red

HLS-640
Light Color:
Up-Green, Down-Red

FLOORING



MATERIAL

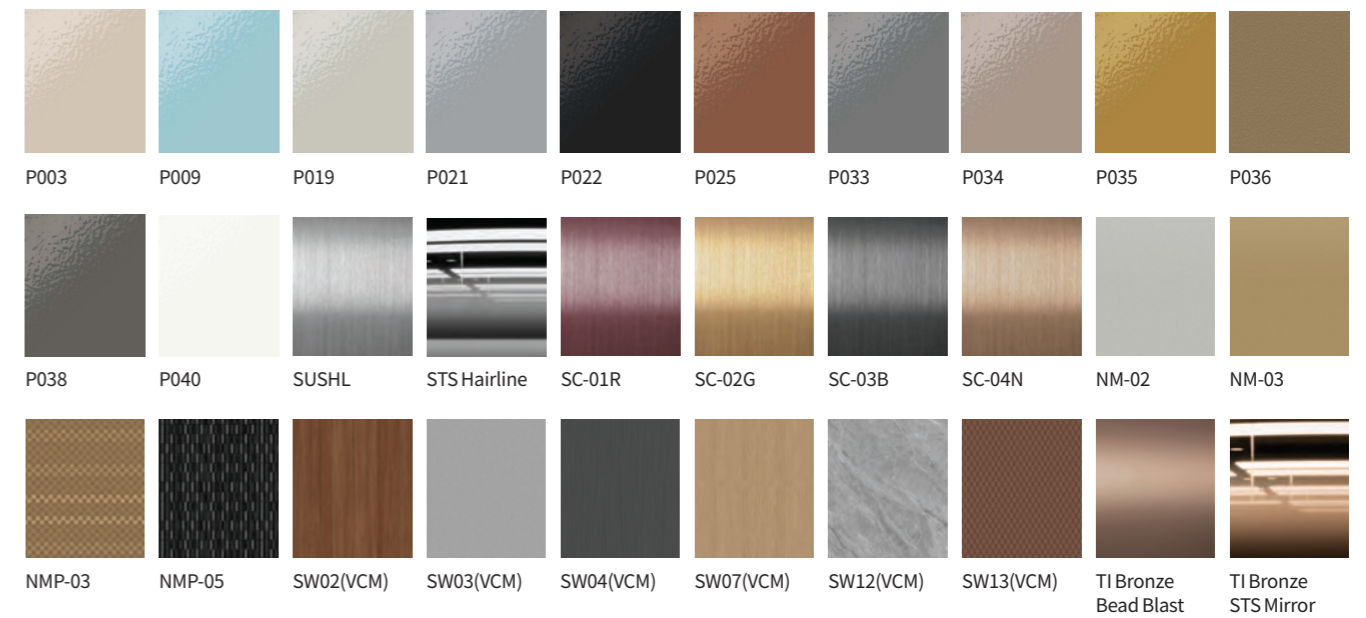

* Four SC type colors are not recommended for sites on a coastal area.

ETCHING

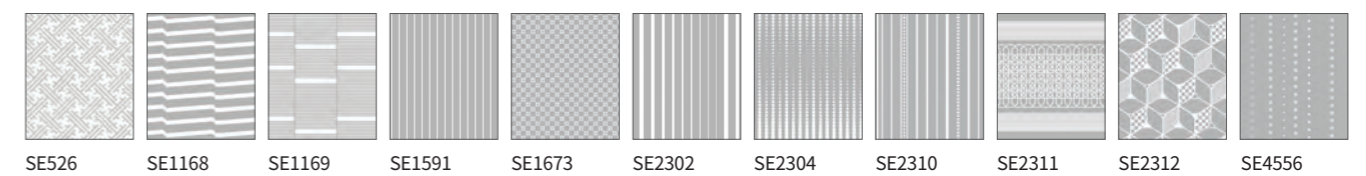

* ■: ▒ Embossed / □: ▒ Intaglio etching part

INSTALLATION LAYOUT PLAN

N:EX-1 MRL, Counterweight Side Drop Type

PLAN OF HOISTWAY

SECTION OF HOISTWAY

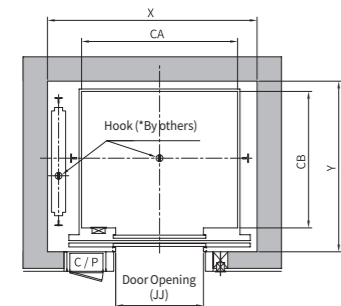

1SCO

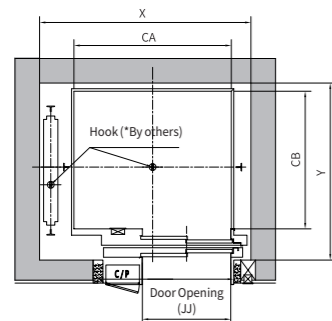

2SSO

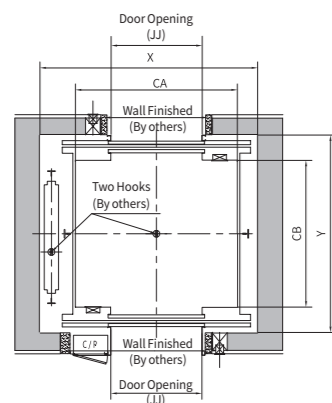

1SCO
Double Entrance

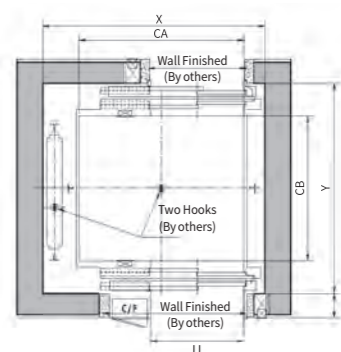

2SSO
Double Entrance

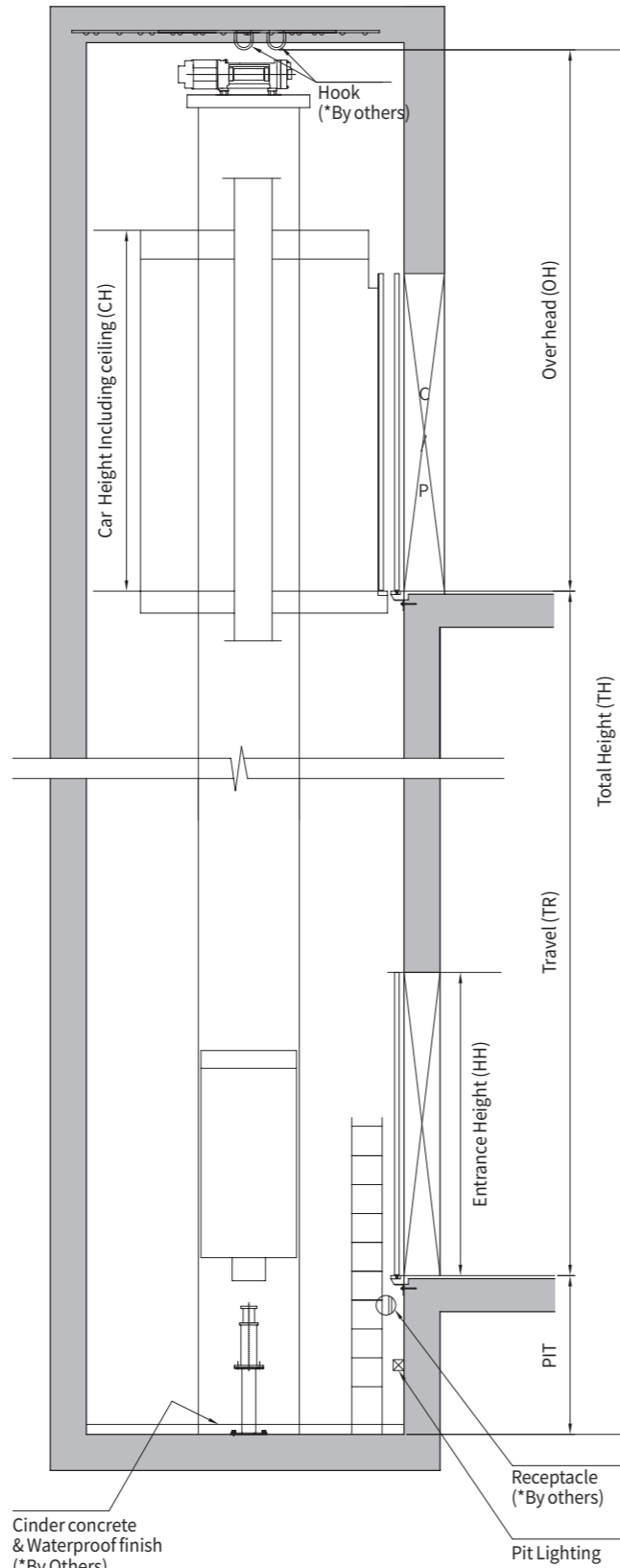

STANDARD DEMENSIONS

(Unit : mm)

Opening Type	Capacity		Speed (m/s)	Car Insize		JJ	HH	Hoistway Insize X × Y	Max Decoration Weight (kg)		
	Persons	kg		CA × CB	CH						
1SCO Single Entrance	P6	450	1.0 1.5 1.75	1100×1150	2300	800	2100	1700×1550	150 (NOTE 1)		
	P7	550		1100×1300				1775×1650			
	P8	630		1100×1400				1775×1750			
	P9	700		1250×1400				1850×1750			
	P10	800		1350×1400				1900×1750			
	P12	900		1500×1400				2100×1750			
2SSO Single Entrance	P13	1000	1600×1400	2150×1750	200	900	2100	2150×1750			
	P15	1150	1800×1400	2350×1750							
	P6	450	1100×1100	1650×1570				105 (NOTE 1)	800	2100	1650×1700
	P7	550	1100×1300	1650×1800							
	P8	630	1100×1400	1750×1800							
	P9	700	1200×1400	1850×1800							
P10	800	1300×1400	1850×2000								
P12	900	1300×1600	2150×1800								
1SCO Double Entrance	P13	1000	1600×1400	1650×2500	155	900	2100	2350×1800			
	P15	1150	1800×1400	1800×2500							
	P7	550	1100×1300	1775×1800				105 (NOTE 1)	800	2100	1775×1900
	P8	630	1100×1400	1850×1900							
	P9	700	1250×1400	1900×1900							
	P10	800	1350×1400	2100×1900							
P12	900	1500×1400	2150×1950								
P13	1000	1600×1450	2350×1950								
2SSO Double Entrance	P15	1150	1800×1400	2350×1950	155	900	2300	1650×1934			
	P7	550	1100×1300	1655×2034				105 (NOTE 1)	800	2100	1750×2034
	P8	630	1100×1400	1850×2034							
	P9	700	1200×1400	1850×2034							
	P10	800	1300×1400	2150×2034							
	P12	900	1300×1600	2150×2034							
P13	1000	1600×1400	2350×2034								

- NOTE:**
- When capacity is 550kg, with travel distance of TR ≤ 25m, there is no additional car weight allowance for interior decoration. If additional weight is required (up to 150kg) additional belt must be applied.
 - Standard Entrance Height(HH) range : 2000mm ≤ HH ≤ 2200mm.
Standard Car Height(CH) range : CH ≤ 2700mm.
 - If required Car Height(CH) exceeds 2300mm and additional car weight for car interior decoration is expected, please consult with us for maximum allowable weight.

OH & PIT Depth (EN81-20/50&EN81-1)

(Unit : mm)

Capacity(kg)	Speed(m/s)	OH(mm)		PIT(mm)
		Balustrade Height 700	Balustrade Height 1100	
450-1150	1.0	3550	3950	1100
	1.5	3700	4100	1250
	1.75	3750	4150	1300

- NOTE:**
- Above table is based on CH=2300mm and HH=2100mm.
 - Car & CWT runby is 120mm.
 - For capacity 450kg with above standard car size, the refuge type in accordance with EN81-20 ("5.2.5.7 ~ 5.2.5.8) is "crouching" on car and "Laying" in pit respectively.
 - For stretcher elevator, please check with your local authorities for the required car and door dimension.
 - Only apply to steel belt number ≤ 3 :
When ceiling is CD-199A and apply car exit, if CA ≥ 1100mm and CB ≥ 1600mm : [OH] is standard values.
 - The minimum floor height is 2,600mm for HL2 door operator and 2,720mm for W1L door operator. Please consult with us if your height is less than 2,720mm.
 - Required OH may be increased if you need to position the ventilation fan in the middle of the ceiling or emergency trap door is applied on the ceiling. Please consult with us for more details.

FUNCTIONS

STANDARD & OPTIONAL FEATURES

Feature	Description	Standard	Optional
Simplex Selective Collective Operation	Operation is carried out completely automatically when a call is registered.	●	
Car Door Safety Edge with Single Side	A safety edge that runs down the full height of the door causes the door to reopen when it detects a person or obstacle while closing.	●	
Automatic Car Light & Fan Turn-off	Car illumination and fan are turned off automatically when the car is idle to save energy.	●	
Landing Door Interlock Switch	A switch integrated into the door operator prevents the car from moving when the doors are open. It locks doors completely while the car is operating to impede the opening of doors from the outside.	●	
Interphone (Intercom)	An interphone system provides emergency communication between passengers in the car and personnel in the machine room, maintenance room, or security office.	●	
Overload Holding Stop	A buzzer sounds and the car does not operate when passenger load exceeds maximum capacity. The buzzer stops, doors close, and the elevator starts to operate when passengers get off and weight is brought below the limit.	●	
Safety Drive Operation	If a car stops between floors during normal operation and the safety device does not work, the car will automatically move to the nearest floor at a low speed, open its doors, and allow passengers to get off.	●	
Parking Operation	Elevators can be automatically parked at a predetermined floor with doors closed and lights and ventilation turned off.		●
Multi-beam Device for Car Doors	Multi-beams from the top to the bottom of the door detect obstructions and force the door to remain open or to reopen before it hits the obstruction.		●
Anti-nuisance Operation	When there is a significantly larger number of calls registered than the number of passengers, the elevator prevents unnecessary operation by canceling all calls entered after it arrives at the nearest floor.		●
Emergency Fire Operation	Cars return to a predetermined floor in the event of fire to help evacuate passengers safely.		●
Voice Synthesizer	A voice synthesizer directs passengers with audible operational information, such as car direction, floor landed, and emergency alerts.		●
Self-generated Power Operation	Power is supplied from the building's power generator and elevators operate under emergency power mode during power outages.		●
Emergency Fireman's Service	Firemen can use elevators parked at a specific floor to support fire-fighting operations in the event of a fire.		●
ELD (Emergency Landing Device)	Elevators are sent to the nearest floor using power from a rechargeable battery when power outages occur and there is no emergency power in order to prevent trapping passengers.		●
Attendant Operation	The elevator's operating mode can be switched from its regular automatic mode to manual mode using the attendant's switch on the COP.		●
Emergency Earthquake Operation	An earthquake sensor detects tremors and forces the elevator to stop at the nearest floor with its door fully open, preventing further operation.		●

WORK TO BE DONE BY OTHERS

CONSTRUCTION WORK

HOISTWAY

- Forming holes on the wall surrounding the entrance on each floor. (entrance, hall button, hall lantern, etc.), and finishing the walls and floors after installation of the elevator. (including mortar filling)
- Installation of steel frame to fix the left / right jambs on the entrance.
- Installation of ladder for pit inspection where there the pit depth not exceeding 2.5m.
- Installation of Pit access door where the pit depth exceeds 2.5m.
- Access door size: Min. 600mm (W) × Min. 2000mm (H)
- Waterproofing work inside the pit and finishing work after installation of the buffer.
- Installation of hoistway partitions or separating beams. (If necessary)
- Removing various tie pins and molds.
- Others. (items indicated on the layout plan)

- Construction of concrete structures (thickness of 150 mm or above) or steel structures to fix the rail brackets.
- Destruction and finishing of concrete structures that are not constructed as indicated on the layout plan.
- Installation of lifting beam or hook that is designed to lift the machine to the top of hoistway.

MACHINE ROOM (MR)

- Forming holes for machines and ropes on the floor, finishing on cinder concrete, and installation of those indicated on the layout plan.
- Installation of lifting beam or hook on the top of machine room.
- Installation of reinforcement beam on the machine room floor. (If necessary)

CONSTRUCTION WORK

HOISTWAY

- The natural or artificial lighting of the landings in the vicinity of landing doors shall be at least 50 lux at floor level.
- Lighting with an intensity of at least 50 lux at 1.0 m above the pit floor everywhere a person can stand and 1.0 m above the car roof within its vertical projection.
- Lighting with an intensity of at least 20 lux in the whole hoistway.
- Piping and wiring work from monitoring panel to hoistway when monitoring panel is installed.
(Wire specifications: 0.75mm x 2, twist cable per one bank(Max. 20 units))
- Piping and wiring work when CCTV is installed.
- Others. (items indicated on the layout plan)
- Wiring work on power system within the hoistway for supplying power and lighting. (Refer to the layout plan for electrical power requirements.)
- Installation of distribution box for elevator (including N.F.B) on electrical room. (Install near the hoistway. Refer to the layout plan for electrical power requirements.)
- Construction for power supply to maintain the voltage regulation of distribution source within ±5% to and lighting within ±2%.
- Piping and wiring work on lighting outlet for pit inspection.
- Supplying power needed during installation and commissioning free of charge.
- Piping and wiring work on emergency communication device between elevator control panel and central control room. (Wire specifications: 0.75mm x 4, twist cable per each elevator)

- ※ Communication device that connects the inside and outside of the elevator should be installed redundantly on the area where the managing personnel is stationed (security office, electric room, and central control room). In case of the facility where the managing personnel is stationed in only one place, only one communication device may be installed.

MACHINE ROOM (MR)

- Piping and wiring work outside the hoistway for the installation of emergency call equipment (intercom) in a place other than the machine room.
- Construction of lighting and lighting outlets for inspection in machine room.
- Supplying power needed during installation and commissioning free of charge.
- Installation of lighting for power system and car, and construction of machine room incoming panel and its wiring for emergency power.
- Lighting with an intensity of at least 200 lux at floor level everywhere a person needs to work and 50 lux at floor level to move between working areas.

MACHINE ROOM LESS (MRL)

- Power supply (Including piping and wiring work) to the control panel and per-manently installed lighting with an intensity of at least 200 Lux from the bottom of the control panel.

MATTERS TO NOTE

- Exit for machine room should be made of fire-proof material and should be installed in a structure that does not lead to other places.
 - Do not install ducts or pipes for other purposes (electricity, water, gas, hydrant) on the hoistway and walls inside the machine room.
 - Lower part of pit should not be used as residence, pathway, or for other purposes.
 - Power and voltage regulation should be within +5% to -5%.
 - Temperature in machine room should be 40°C and humidity should be 90% or below. Be sure to install the entilation window, ventilator, or other air-conditioning facilities to prevent generation of dust or poisonous gas inside the machine room.
- ※ When you wish to build the hoistway in steel frame, please contact us. (Steel frame construction for hoistway is excluded from our supply scope.)

- ※ Construction errors: Inner hoistway size that is indicated on the blueprint of this catalog is the minimum size that is designed to fit the size of the elevator interior. So, the construction error limit for hoistway width and overall height is ±20 mm.
- ※ Calculation equation for heat generation in machine room (based on one elevator)
- $$Q: (\text{kcal/H}) = W \times V \times F \times N$$
- W: Loading capacity (kg)
N: Number of elevators
V: Rated speed (m/min.)
F: Coefficient based on control type (1/42: VVVF)

